

Esquema da eletronica Jato F5 Pusher.

Peças e sequência de montagem:

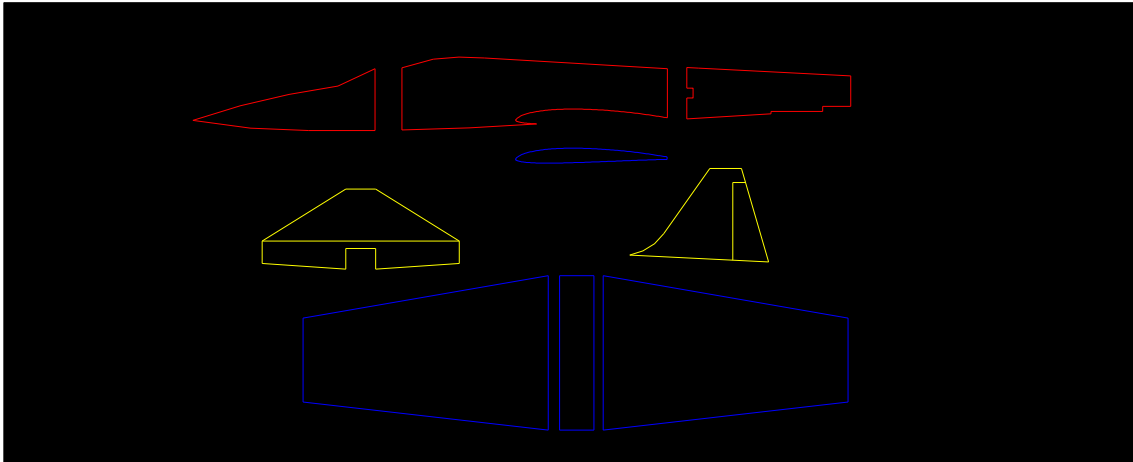

Montagem da fuselagem :

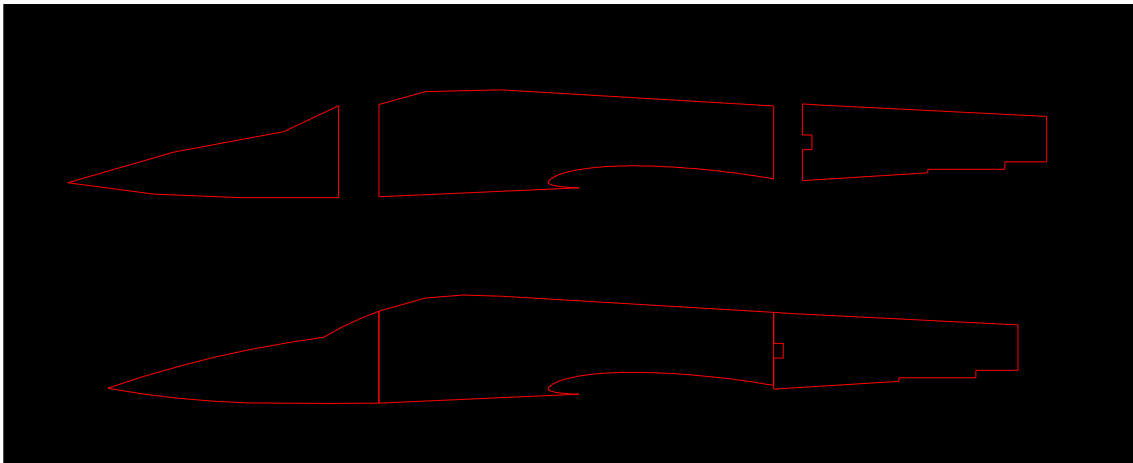

Leme e profundor:



Colocação servos , leme e profundor:

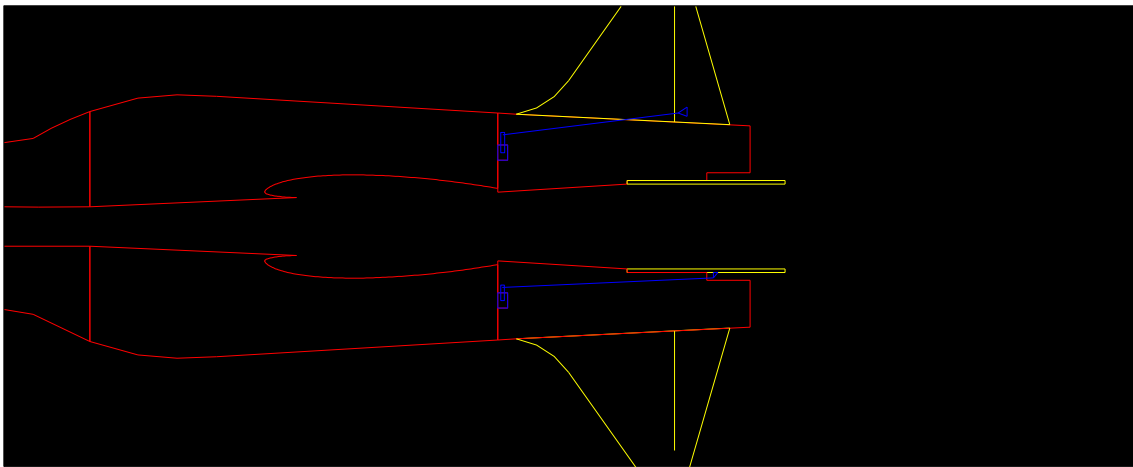
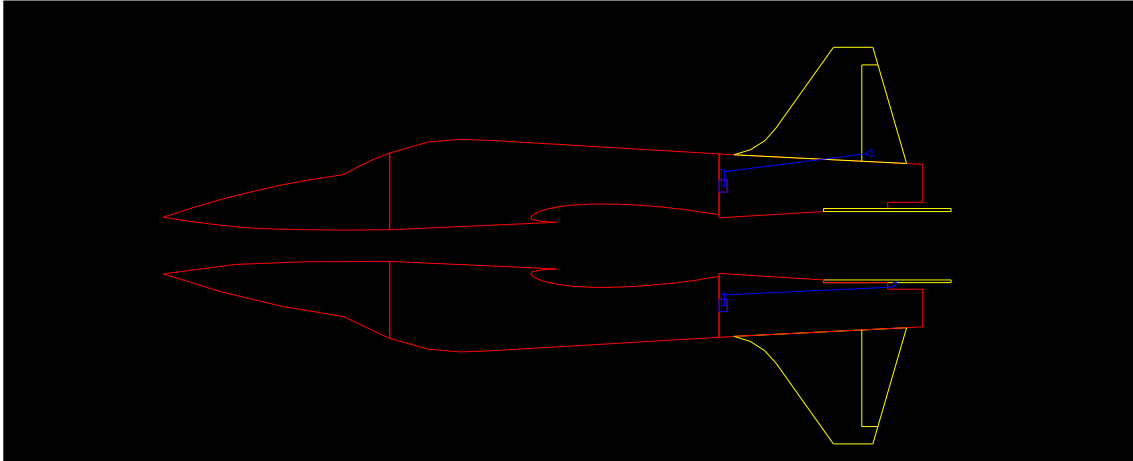

Fixação motor :

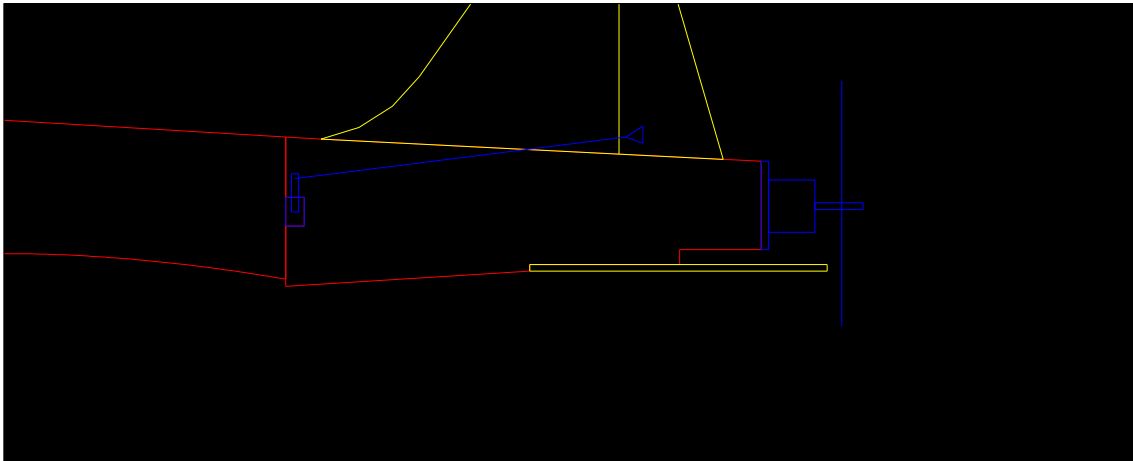

Montagem da asa:

Fibra de vidro posicionada uma em cima e outra em baixo:

Caso receba seu kit sem o corte dos aileron a medida esta na 2ª imagem

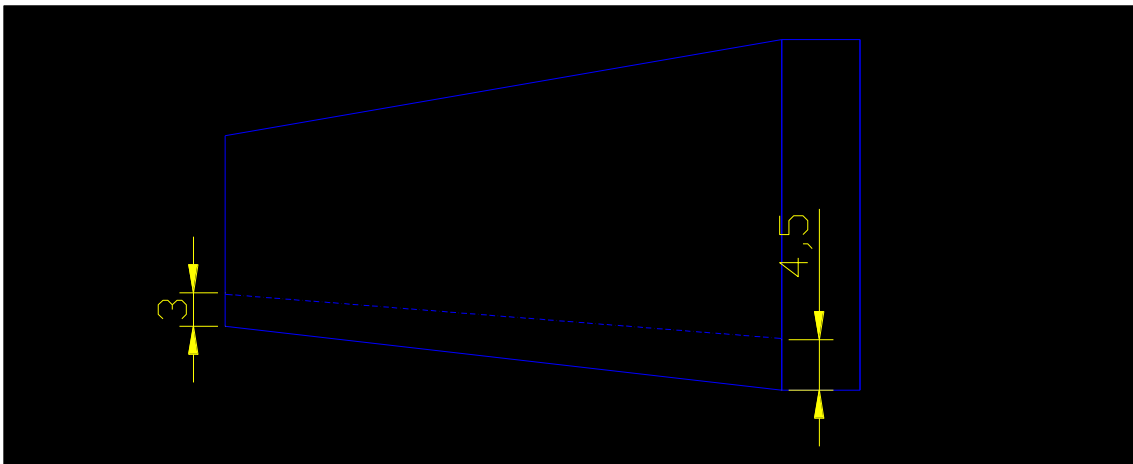
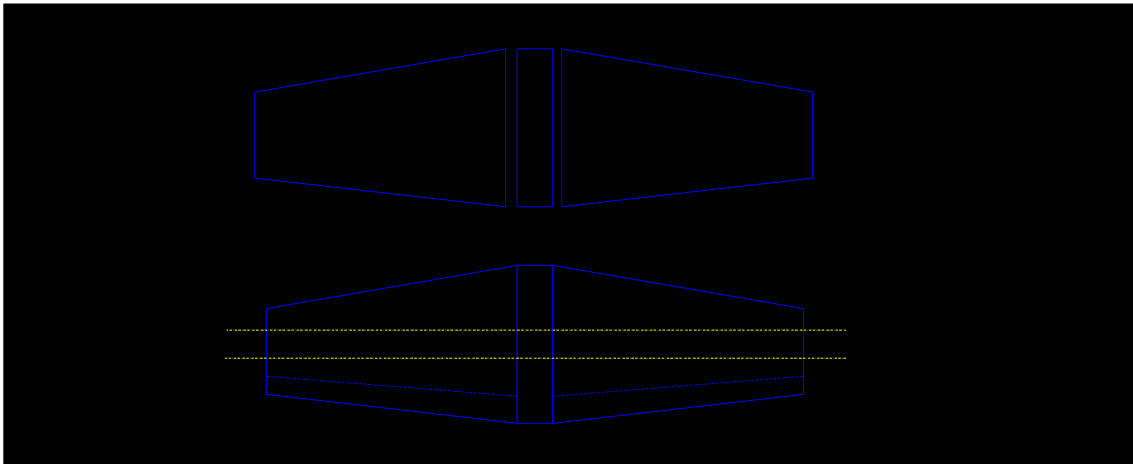

Ao cortar o aileron não esqueça do corte de 45°

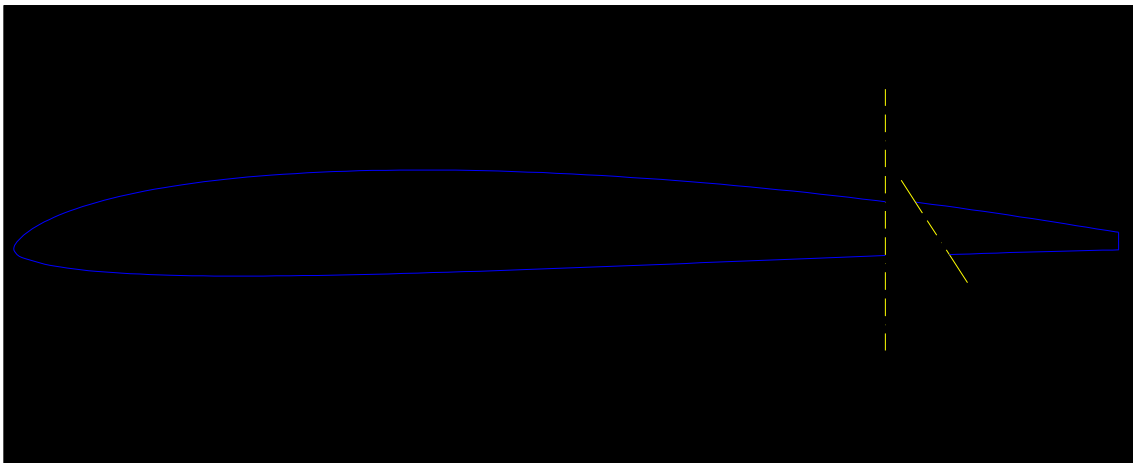

Colocação servos na asa:

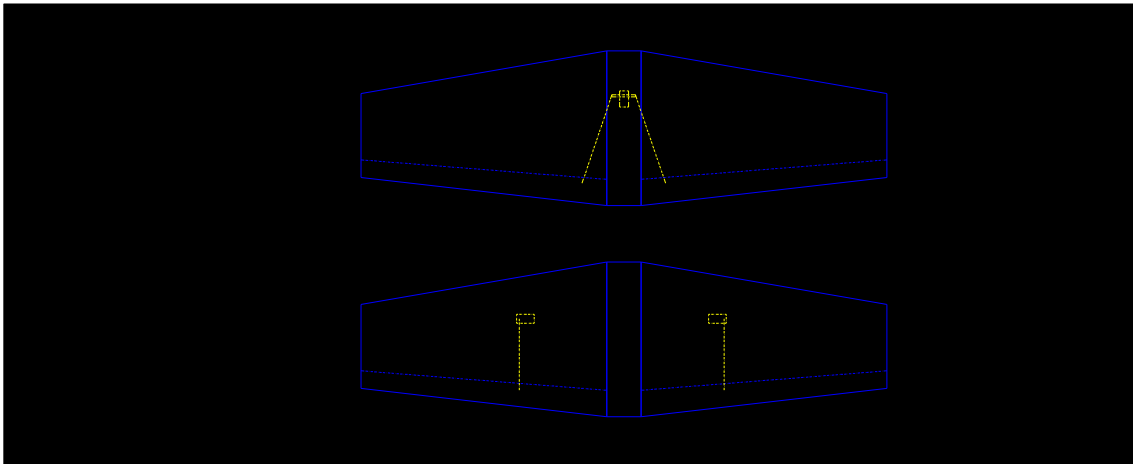

Fixação da asa com elásticos:

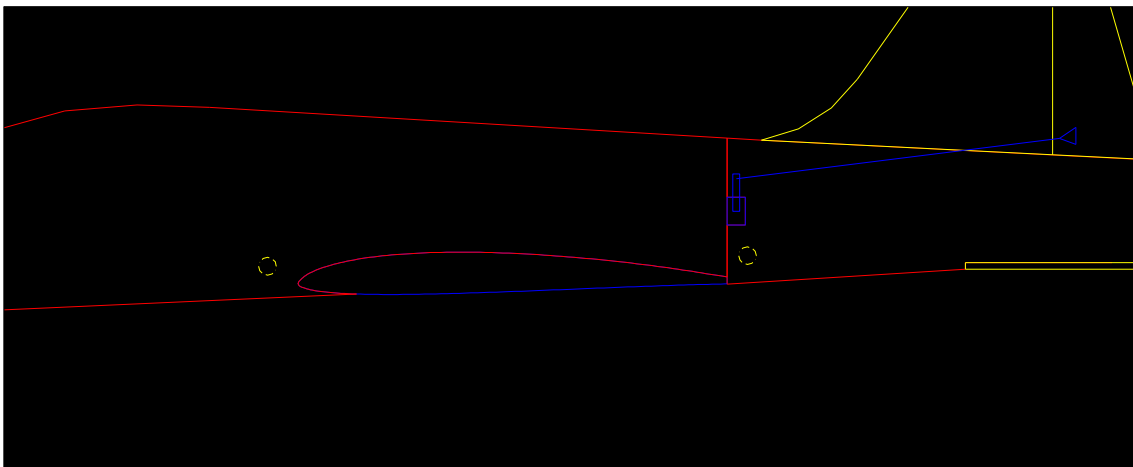

Distribuição da eletrônica na fuselagem:

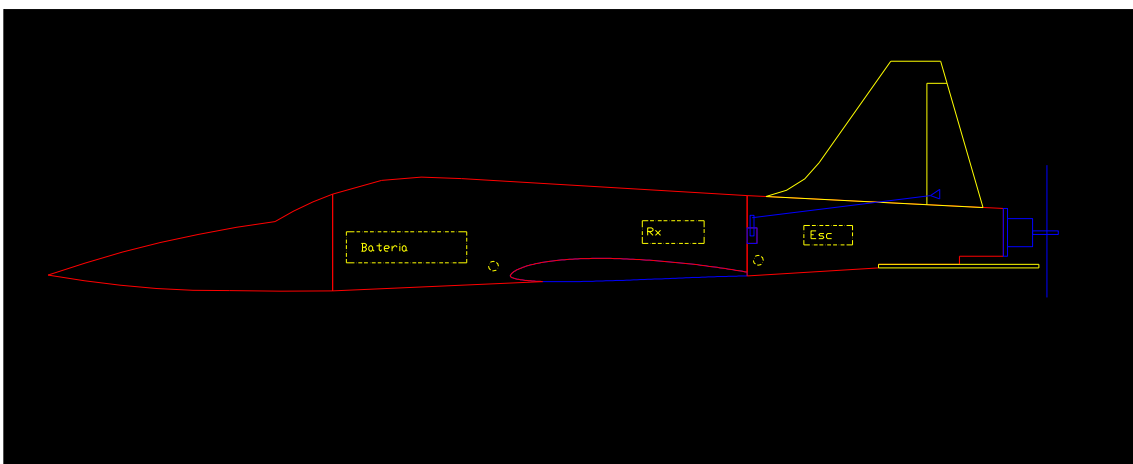

Segue a imagem com cg do aereo:

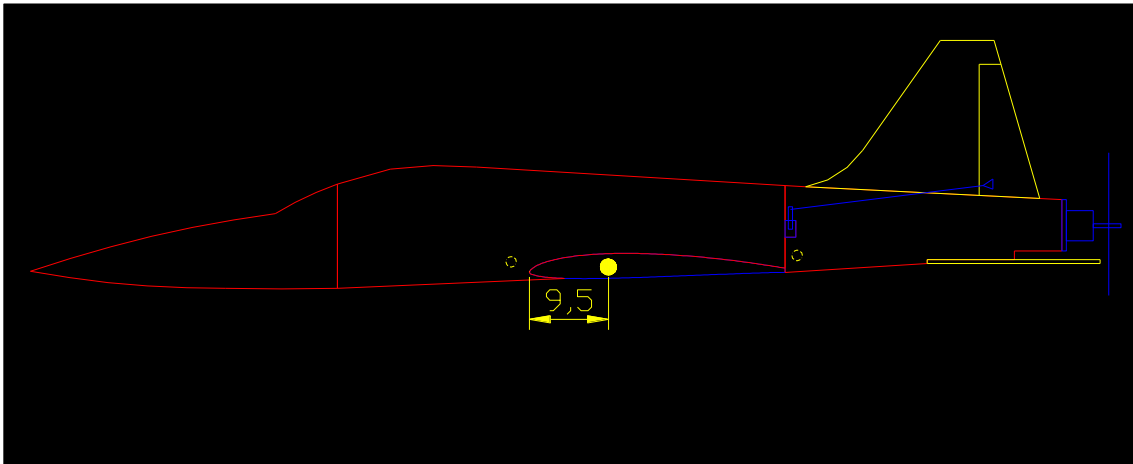

Recomenda servos de 9gr , bateria de 2.2 3s, motor 2200kv 2826 e esc de 40 amp

Bons Vôos